

MLG45PDB

MAYTAG® COMMERCIAL
DEPENDABLE CARE®
MULTI-LOAD STACK DRYER



LEGENDARY MAYTAG DEPENDABILITY

Maximizing your equipment investment for over a half century.



MICROPROCESSOR CONTROLS

Maytag® Computer Trac® controls let you adjust prices by cycle, day and time—and they provide simple one-touch cycle selection.

BUILT LIKE A TANK

The MLG45PDB is one of the heaviest 45-pound stack dryers on the market, offering years of dependable Maytag performance.

FOR YOUR CUSTOMERS:

- Fast-Drying Axial Airflow System
- ThermoGuard™ System Helps Prevent Laundry Overheating
- Extra-Large Door Openings
- Time Remaining Digital Display
- Microprocessor Controls

FOR YOUR OPERATION:

- Single Coin Box For Both Dryers
- Front Access For Easier Self Service
- Two 8" Vents Or One Optional 10" Vent
- 2 Large-Capacity Lint Drawers

BUILT-TO-LAST™ FEATURES:

- Heavy-Duty Enclosed Motors
- Permanently Lubricated Bearings
- Rear Belt Drive System
- Best Warranty In The Business—5 Years On All Parts



LAUNDRY SOLUTIONS
YOU CAN *DEPEND* ON.

THERMOGUARD™ SYSTEM
PROTECTS LAUNDRY
AGAINST OVERHEATING

visit maytagcommerciallaundry.com



OUR COMMITMENT TO DEPENDABLE QUALITY

At Maytag, we believe durable goods should remain just that. That's why every Maytag® product is constructed of the highest-quality materials and with the utmost in precision craftsmanship. It's also why we stand behind our equipment with solid service and support from our professional Maytag laundry suppliers. Simply put, when you choose Maytag® products, you ensure your peace of mind.



MLG45PDB

MAYTAG® COMMERCIAL DEPENDABLE CARE® MULTI-LOAD STACK DRYER

Maytag® Commercial Dependable Care® Multi-Load Stack Dryer

MICROPROCESSOR COIN-DROP

DRYER SPECIFICATIONS	
MODEL	MLG45PDB
MOTOR	
Single-phase, thermoprotected against overload, auto-reset	•
HP (kw)	.75 (.56)
Tumble Speed — rpm	43 + 1
CAPACITY	
Lbs. (kg) per drying chamber	45 (20.41)
Cu. ft. (L) per drying chamber	14.6 (413.43)
AIRFLOW	
Cfm (cmm) per drying chamber	600 (16.99)
TUMBLERS	
Diameter — in. (mm)	2-32.75 (2-831.9)
Depth — in. (mm)	2-30 (2-762)
DOOR OPENING DIAMETER	
In. (mm)	27 (686)
ELECTRICAL REQUIREMENTS	120V, 60 Hz
Export Models — options available	208 – 240V/1PH or 3 PH
BREAKER/FUSE REQUIREMENTS	
Amps per drying chamber	15
EXHAUST DUCT DIAMETER	
In. (mm)	2-8 (203) or 1-10 (254)
GAS RATING	
BTU/hr. (kcal/hr.) per drying chamber	112,000 (28,230)
GAS INLET PER POCKET	
M.N.P.T. in. (mm)	1 inlet, 3/4 (19)
ADJUSTABLE LEVELING LEGS	•
COLORS	
White	•
Stainless Steel	•
APPROXIMATE WEIGHT	
Crated — lbs. (kg)	1080 (490)
Uncrated — lbs. (kg)	1015 (460)
DIMENSIONS	
Height — in. (mm)	81 (2057)
Width — in. (mm)	34.25 (870)
Depth — in. (mm)	52.5 (1334)
Door opening diameter — in. (mm)	27 (686)
See specific instructions for proper installation. Because of continuous product improvement, Maytag reserves the right to change specifications without notice.	

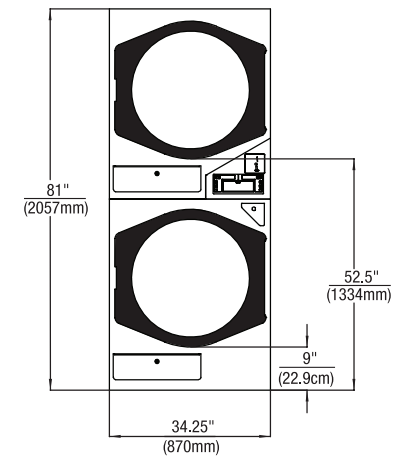

FRONT VIEW

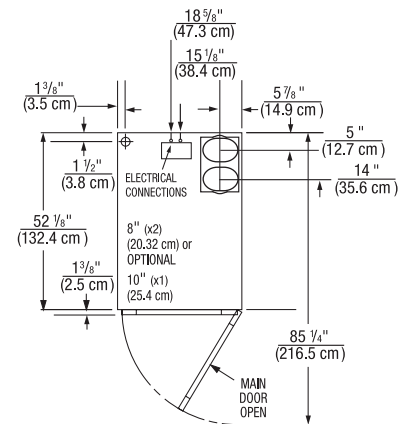

TOP VIEW

*Dimensions will vary according to adjustment of leveling legs; add 1/2" (1.3 cm) minimum.



NEW YORK CITY M.E.A.



THE BEST WARRANTY IN THE BUSINESS— 5 YEARS ON ALL PARTS

For a period from the date of original purchase through the time listed above, the designated parts that fail in normal commercial use will be repaired or replaced free of charge for the part itself, with the owner paying all other costs, including labor, transportation and customs duty. Chemical damage is excluded from all warranty coverage. See complete warranty for details.

For more information and pricing, contact:

Equipment Marketers

100 Melrose Avenue
Cherry Hill, NJ 08003

Phone: 800.223.1376

Fax: 856.428.5477

www.equipmentmarketers.net maytag@equipmentmarketers.net