

MLG31PC

MAYTAG® COMMERCIAL
MULTI-LOAD STACK DRYER



LEGENDARY MAYTAG DEPENDABILITY

Maximizing your equipment investment for over a half century.



FAST, EFFICIENT DRYING IN LESS FLOOR SPACE

The MLG31PC offers a 42³/₄" footprint depth—one of the smallest in the industry. You can fit two 30-pound dryer pockets in the same floor space as one conventional multi-load dryer.

MICROPROCESSOR CONTROLS

Programmable controls let you adjust pricing at the touch of a button. Microprocessor coin-drop helps prevent slugging.

FOR YOUR CUSTOMERS:

- Fast-Drying Axial Airflow System
- Extra-Large Door Openings
- Digital Display Shows Time Remaining In Cycle

FOR YOUR OPERATION:

- Single Coin Box For Both Dryers
- Front Access For Easy Service
- Two 6" Vents Convert To one 10" Vent
- Two Large-Capacity Lint Drawers

BUILT-TO-LAST™ FEATURES:

- Heavy-Duty Enclosed Motors
- Permanently Lubricated Bearings
- The Best Warranty In The Business



LAUNDRY SOLUTIONS
YOU CAN *DEPEND* ON.

SMALLER FOOTPRINT REQUIRES
LESS FLOOR SPACE

visit maytagcommerciallaundry.com
or call 800-662-3587



OUR COMMITMENT TO DEPENDABLE QUALITY

At Maytag, we believe durable goods should remain just that. That's why every Maytag® product is constructed of the highest-quality materials and with the utmost in precision craftsmanship. It's also why we stand behind our equipment with solid service and support from our professional Maytag laundry suppliers. Simply put, when you choose Maytag® products, you ensure your peace of mind.



MLG31PC MAYTAG® COMMERCIAL MULTI-LOAD STACK DRYER

Maytag® Commercial Multi-Load Stack Dryer MICROPROCESSOR COIN-DROP

DRYER SPECIFICATIONS	
MODEL	MLG31PC
MOTOR	
Single-phase, thermoprotected against overload, auto-reset	•
HP (kw)	1/2 (.249)
CAPACITY	
Lbs. (kg)	30 (13.6)
Cu. ft. (cu. m)	10.1 (.287)
AIRFLOW	
Cfm (cmm) per drying chamber	400 (11.3)
TUMBLER	
Diameter — in. (cm)	27 1/4 (69.2)
Depth — in. (cm)	30 (76.2)
DOOR OPENING DIAMETER	
In. (cm)	21 1/2 (54.6)
ELECTRICAL REQUIREMENTS	120V, 60 Hz
BREAKER/FUSE REQUIREMENTS	
Amps per drying chamber	15
EXHAUST DUCT DIAMETER	
1 inlet — in. (cm)	10 (25.4)
2 inlets — in. (cm)	6 (15.2)
GAS RATING	
BTU/hr. (kcal/hr.) per drying chamber	68,000 (17,135)
GAS INLET PER POCKET	
In. (cm)	1/2 (1.3)
ADJUSTABLE LEVELING LEGS	•
COLORS	
White	•
Bisque	•
Stainless Steel	•
APPROXIMATE WEIGHT	
Crated — lbs. (kg)	860 (390.1)
Uncrated — lbs. (kg)	793 (359.7)

See specific instructions for proper installation. Because of continuous product improvement, Maytag reserves the right to change specifications without notice.

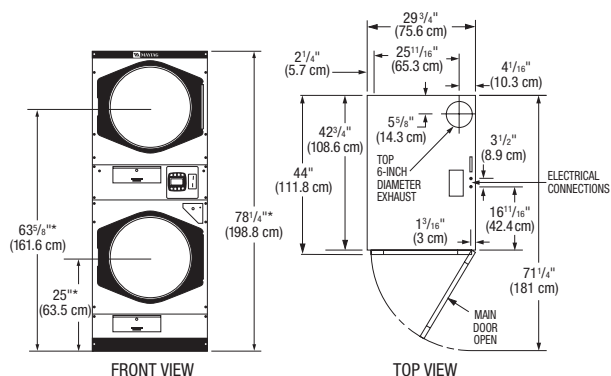

*Dimensions will vary according to adjustment of leveling legs; add 1/2" (1.3 cm) minimum.



NEW YORK CITY
M.E.A.



THE BEST WARRANTY IN THE BUSINESS— 5 YEARS ON ALL PARTS

For a period from the date of original purchase through the time listed above, the designated parts that fail in normal commercial use will be repaired or replaced free of charge for the part itself, with the owner paying all other costs, including labor, transportation and customs duty. Chemical damage is excluded from all warranty coverage. See complete warranty for details.

For more information and pricing, contact:

Equipment Marketers

100 Melrose Avenue
Cherry Hill, NJ 08003

Phone: 800.223.1376

Fax: 856.428.5477

www.equipmentmarketers.net

maytag@equipmentmarketers.net