

# MAT14PD

MAYTAG® COMMERCIAL  
ENERGY ADVANTAGE™  
TOP-LOAD WASHER



## LEGENDARY MAYTAG DEPENDABILITY

Maximizing your equipment investment for over a half century.



### FOR YOUR CUSTOMERS:

- Proven Cleaning Performance
- Extra-Large Lid And Tub Opening
- Easy-To Use One-Touch Cycle Selection
- Flexible Wash Options
- Time Remaining Display

### FOR YOUR OPERATION:

- The Most-Efficient, Best-Cleaning Top-Load Washer From Maytag
- Super Cycle Option Increases Revenue
- Self-Diagnostic Feature Cuts Service Costs And Minimizes Downtime
- Front Access For Easier Self-Service
- Accu Trac® Audit System With Two-Way Data Communication
- Debit Card Compatibility
- Advanced Computer Trac® Controls Allow For Easy Programming
- Dual Coin-Drop Option

### BUILT-TO-LAST™ FEATURES:

- Premium Porcelain-Enamel Top
- Beltless Design
- Dependable Direct Drive Transmission
- Self Cleaning Pump
- High Security Vault
- Best Warranty In The Business — 5 Years All Parts



LAUNDRY SOLUTIONS  
YOU CAN *DEPEND* ON.

REDUCES WATER USAGE  
BY 25%\*

\*Compared to Maytag® top-load washers manufactured before 2005.

visit [maytagcommerciallaundry.com](http://maytagcommerciallaundry.com)

CLP790A



## OUR COMMITMENT TO DEPENDABLE QUALITY

At Maytag, we believe durable goods should remain just that. That's why every Maytag® product is constructed of the highest-quality materials and with the utmost in precision craftsmanship. It's also why we stand behind our equipment with solid service and support from our professional Maytag laundry suppliers. Simply put, when you choose Maytag® products, you ensure your peace of mind.



## MAT14PD MAYTAG® COMMERCIAL ENERGY ADVANTAGE™ TOP LOAD WASHER

### Maytag® Energy Advantage™ Top-Load Washer MICROPROCESSOR COIN-DROP

WASHER SPECIFICATIONS	
<b>MODEL</b>	<b>MAT14PD</b>
<b>MOTOR</b>	
Single-phase, reversible, thermoprotected, high torque	•
HP (kw)	½ (.37)
<b>APPROXIMATE WATER USAGE</b> — gallons (liters)	
Average hot water usage per cycle	3.7 (14)*
Average total water usage per cycle	23.2 (87.8)*
<b>ELECTRICAL RATING</b>	
Voltage	120V/60 Hz
<b>BREAKER/FUSE REQUIREMENT</b>	
AMPS	15
<b>CYLINDER</b>	
Volume — cu. ft. (liters)	2.5 (70.8)
Diameter — in. (mm)	18.4 (468)
Depth — in. (mm)	17.8 (454)
<b>LID OPENING</b>	
In. (mm)	18 (457)
<b>EXTRACT SPEED</b>	
Maximum rpm	640
Maximum g-force	107
<b>OPERATING PRESSURE</b>	
Psi (bar)	20-100 (1-8)
<b>INLET HOSE LENGTH</b>	
Ft. (m)	4.5 (1.37)
<b>DRAIN HOSE LENGTH</b>	
Ft. (m)	4.4 (1.34)
<b>APPROXIMATE WEIGHT</b>	
Crated — lbs. (kg)	178 (80.7)
Uncrated — lbs. (kg)	164 (74.4)
<b>DIMENSIONS</b>	
Height — in. (mm)	43 (1092.2)
Width — in. (mm)	27 (686)
Depth — in. (mm)	25.5 (648)

\* Average based on DOE J1 testing with factory preset cycles.  
See specific instructions for proper installation. Because of continuous product improvement, Maytag reserves the right to change specifications without notice.  
\*\* Height at metercase top does not include pedestal.

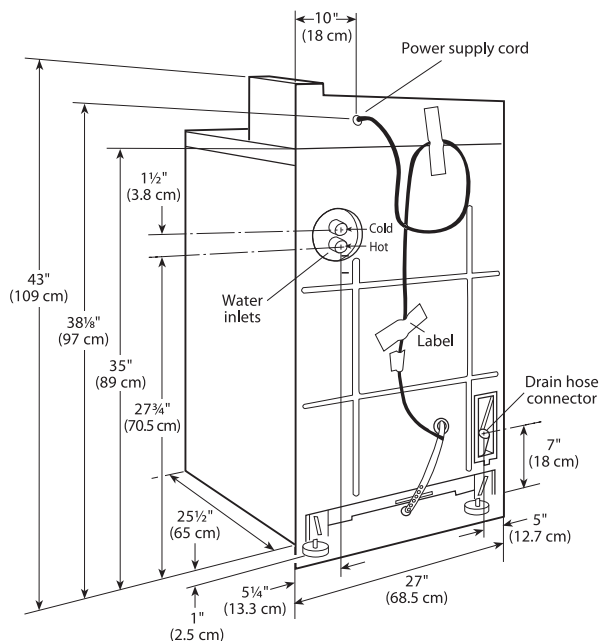

NEW YORK CITY  
M.E.A.



### THE BEST WARRANTY IN THE BUSINESS— 5 YEARS ON ALL PARTS

For a period from the date of original purchase through the time listed above, the designated parts that fail in normal commercial use will be repaired or replaced free of charge for the part itself, with the owner paying all other costs, including labor, transportation and customs duty. Chemical damage is excluded from all warranty coverage. See complete warranty for details.

For more information and pricing, contact:

## Equipment Marketers

100 Melrose Avenue  
Cherry Hill, NJ 08003

Phone: 800.223.1376  
Fax: 856.428.5477

[www.equipmentmarketers.net](http://www.equipmentmarketers.net) [maytag@equipmentmarketers.net](mailto:maytag@equipmentmarketers.net)