

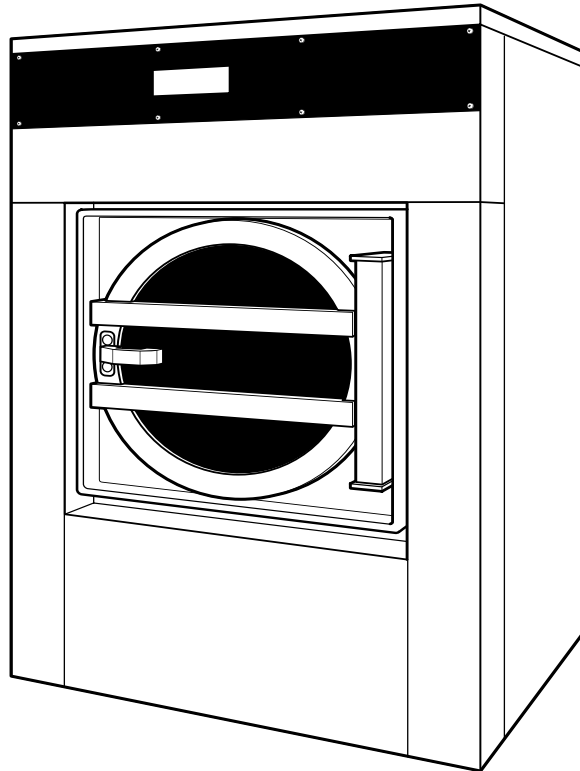

# INSTALLATION INSTRUCTIONS

## MFS18, MFS25, MFS35, MFS55

### COMMERCIAL WASHER



## TABLE OF CONTENTS

<p><b>WASHER SAFETY</b> ..... 2</p> <p><b>INSTALLATION REQUIREMENTS</b> ..... 3</p> <p>  Tools and Parts..... 3</p> <p>  Optional Equipment ..... 3</p> <p>  Location Requirements ..... 3</p> <p>  Electrical Requirements ..... 6</p> <p>  Water Supply Requirements ..... 7</p> <p>  Drain Requirements ..... 7</p> <p>  Laundry Product Dispenser Pumps ..... 7</p> <p><b>INSTALLATION INSTRUCTIONS</b> ..... 8</p> <p>  Inspection and Storage ..... 8</p> <p>  Mechanical Installation ..... 8</p> <p>  Remove Shipping Brackets ..... 8</p> <p>  Electrical Connection ..... 9</p> <p>  Water Supply Connection ..... 9</p> <p>  Drain Connection ..... 9</p> <p>  Laundry Product Supply Pump Connection ..... 9</p> <p>  Complete Installation ..... 10</p> <p>  Break-In Period ..... 10</p> <p>  Controls Troubleshooting ..... 10</p>	<p><b>WASHER MAINTENANCE</b> ..... 11</p> <p>  Maintenance Schedule..... 11</p> <p>  Vibration Switch Adjustment and Function Test ..... 11</p> <p>  Belt Inspection, Adjustment, and Replacement..... 12</p> <p>  Door Seal Adjustment and Replacement..... 12</p> <p>  Fuse Replacement ..... 13</p> <p>  Opening Door Without Power ..... 13</p> <p><b>DIMENSIONS AND TECHNICAL SPECIFICATIONS</b>..... 14</p> <p>  Dimensions..... 14</p> <p>  Component Locations..... 15</p> <p>  Technical Specifications..... 16</p> <p>  Torque Specifications ..... 16</p>
---	--

For more information and pricing, contact:

*Equipment Marketers*

100 Melrose Avenue                      Phone: 800.223.1376  
 Cherry Hill, NJ 08003                      Fax: 856.428.5477  
[www.equipmentmarketers.net](http://www.equipmentmarketers.net)    [maytag@equipmentmarketers.net](mailto:maytag@equipmentmarketers.net)

**W10214572B**

[www.maytagcommerciallaundry.com](http://www.maytagcommerciallaundry.com)

## WASHER SAFETY

### Your safety and the safety of others are very important.

We have provided many important safety messages in this manual and on your appliance. Always read and obey all safety messages.



This is the safety alert symbol.

This symbol alerts you to potential hazards that can kill or hurt you and others.

All safety messages will follow the safety alert symbol and either the word "DANGER" or "WARNING."

These words mean:

**⚠ DANGER**

You can be killed or seriously injured if you don't immediately follow instructions.

**⚠ WARNING**

You can be killed or seriously injured if you don't follow instructions.

All safety messages will tell you what the potential hazard is, tell you how to reduce the chance of injury, and tell you what can happen if the instructions are not followed.

### IMPORTANT SAFETY INSTRUCTIONS

**WARNING:** To reduce the risk of fire, electric shock, or injury to persons when using the washer, follow basic precautions, including the following:

- Read all instructions before using the washer.
- Do not wash articles that have been previously cleaned in, washed in, soaked in, or spotted with gasoline, dry-cleaning solvents, other flammable, or explosive substances as they give off vapors that could ignite or explode.
- Do not add gasoline, dry-cleaning solvents, or other flammable, or explosive substances to the wash water. These substances give off vapors that could ignite or explode.
- Under certain conditions, hydrogen gas may be produced in a hot water system that has not been used for 2 weeks or more. HYDROGEN GAS IS EXPLOSIVE. If the hot water system has not been used for such a period, before using the washing machine, turn on all hot water faucets and let the water flow from each for several minutes. This will release any accumulated hydrogen gas. As the gas is flammable, do not smoke or use an open flame during this time.
- Do not allow children to play on or in the washer. Close supervision of children is necessary when the washer is used near children.
- Before the washer is removed from service or discarded, remove the door or lid.
- Do not reach into the washer if the drum, tub or agitator is moving.
- Do not install or store the washer where it will be exposed to the weather.
- Do not tamper with controls.
- Do not repair or replace any part of the washer or attempt any servicing unless specifically recommended in this manual or in published user-repair instructions that you understand and have the skills to carry out.
- See "Electrical Requirements" for grounding instructions.

### SAVE THESE INSTRUCTIONS

#### IMPORTANT:

- This washer must be directly wired to the electrical system and may not be attached with a plug.
- The circuit must be a dedicated circuit and may not be combined with any lighting circuit.
- Adequate grounding is essential to washer operation.

---

# INSTALLATION REQUIREMENTS

---

## Tools and Parts

Gather the required tools and parts before starting installation. Read and follow the instructions provided with any tools listed here.

### Tools needed:

These washers must be installed by professional installers. The installer should have a full compliment of standard SAE and metric hand tools as well as other specialized tools as required.

### Additional materials required:

Additional materials required vary with the type of installation. The customer is responsible for supplying additional hardware and adapters as necessary.

### Parts supplied:

Remove parts bag from washer drum. Check that all parts were included. The number of parts supplied varies with model.

- Molded rubber drain hose and band clamp
- Rubber washers for the hoses (4 or 6)
- Water supply hoses (2 or 3)

---

## Optional Equipment

The following optional equipment is available for these washers.

---

### Steam Heater Kit

---

Steam heating kits are available for Model MFS55 only. To add a steam kit to your washer, order the kit specified in the table below:

Model	Steam Kit Number
MFS55PNA	W10308483

## Location Requirements

Washers should be installed on a level concrete floor on the ground level of a building; they can also be installed on an elevated concrete pad up to 12" (300 mm) above the surrounding floor. Consult a structural engineer to approve other locations. The 18 and 25 lb. washers can also be mounted on an elevated metal base up to 12" (300 mm) high.

Proper installation is your responsibility. The installation must meet all governing codes and ordinances.

### You will need:

- The washer should be located in a building and not directly exposed to the weather. The temperature of the building should be 40–95°F (5–35°C) during operation.
- A hot water heater set between 120–160°F (49–80°C).
- Valved hot and cold water supply (3/4" male NPT fitting) within 4 ft. (1.2 m) of the washer with a water pressure between 43 and 73 PSI (0.3–0.5 MPa).
- A dedicated, GFCI-equipped circuit for each washer (see "Electrical Requirements").
- Adequate sanitary sewer drainage located behind the washers.
- A solid concrete floor or slab capable of withstanding the weight and vibration produced by the washer. The maximum slope of the floor is 1" (25 mm) under the washer. A rough concrete surface is preferable to a smooth or covered surface when the washer is not secured, to keep the washer from walking during extraction cycles.

### Minimum Installation Clearances:

The location must be large enough to allow the washer door to open completely.

- There should be adequate access behind and above the washer for maintenance and service.

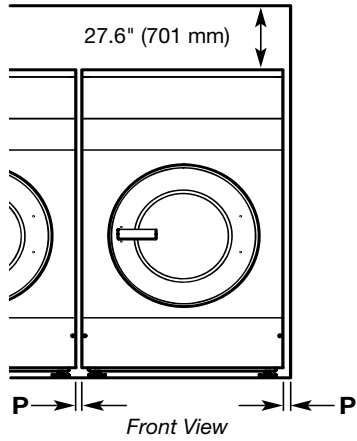

	MFS18	MFS25	MFS35	MFS55
<b>P</b>	0.6" (15 mm)	0.6" (15 mm)	0.8" (20 mm)	0.8" (20 mm)

\* Door may not open completely with this minimum clearance

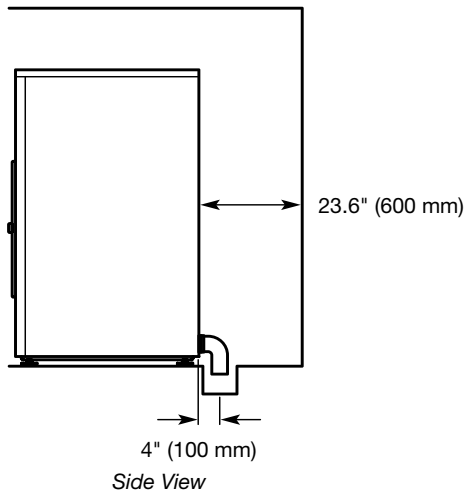

### Product Dimensions

General product dimensions are shown below. See Technical Specifications for dimensions not shown here.

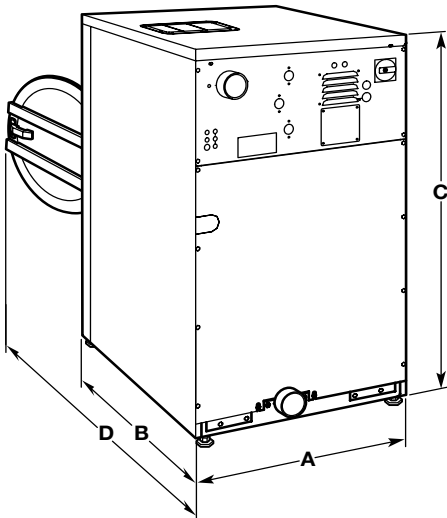

Dim.	Model			
	MFS18	MFS25	MFS35	MFS55
<b>A</b>	25.99" (660 mm)	25.99" (660 mm)	32.67" (830 mm)	35.46" (901 mm)
<b>B</b>	28.15" (715 mm)	32.48" (825 mm)	38.39" (975 mm)	36.40" (925 mm)
<b>C</b>	42.50" (1080 mm)	44.90" (1140 mm)	51.00" (1300 mm)	56.30" (1430 mm)
<b>D</b>	44.50" (1130 mm)	48.40" (1230 mm)	58.70" (1490 mm)	63.60" (1620 mm)

### Installation on an elevated base

#### NOTES:

- Models MFS35 and MFS55 are mountable on either a metal base or an elevated cement slab; however, they must be adequately secured.
- Minimum clearances should be maintained when installing washers in an elevated position.

### Fixed Installation on Concrete Floor or Elevated Concrete Pad (all models)

All washer models can be installed on an elevated cement slab. The base must be able to withstand both the load and vibration of the washer. The washer must be secured with anchor bolts (See "Installation Instructions"). Install the 4 anchors before final installation of the washer.

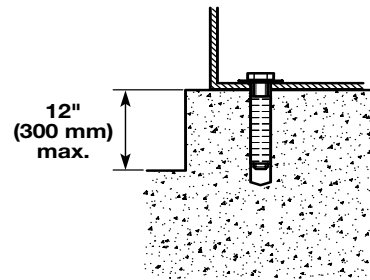

### Freestanding Installation on Elevated Concrete Pad (Models MFS18 and MFS25 only)

Models MFS18 and MFS25 can be installed on an elevated concrete pad without bolts by installing a metal channel at the front of the concrete pad to secure the front washer mounting feet. Specifications of the metal channel are shown in the figure below. The channel must be firmly secured with anchors or self-tapping cement screws.

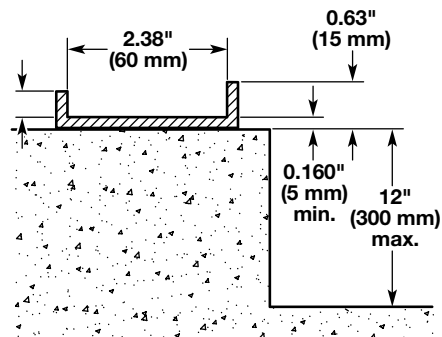

### Elevated Metal Base for Secured Installation

The elevated metal base for a secured installation may be fabricated from a metal U-channel as shown in the illustration below. The maximum allowable height of the base is 12" (300 mm). The base must be able to withstand both the load and vibration of the washer. The base must be adequately secured with anchor bolts or cement anchors.

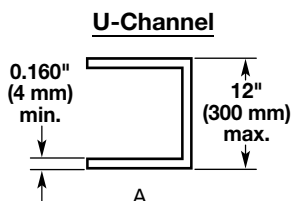
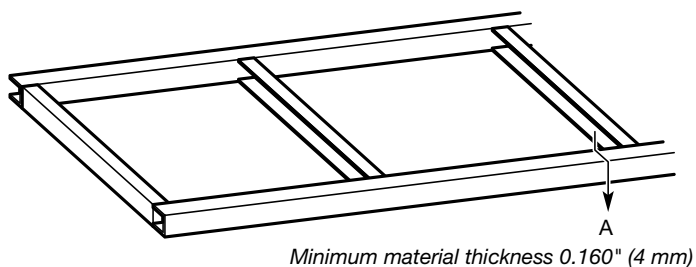

### Anchor Bolt Placement

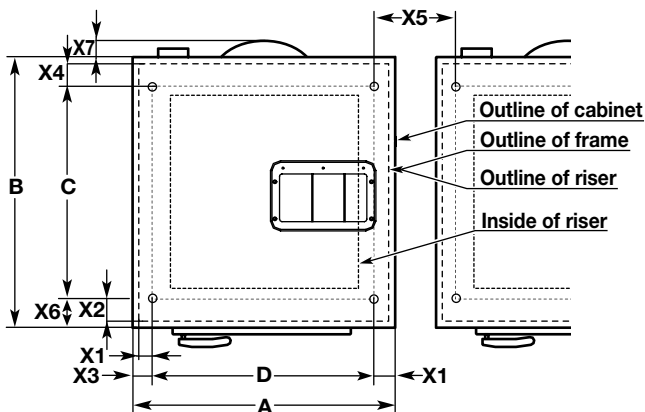

Dim.	Model			
	MFS18	MFS25	MFS35	MFS55
<b>X4</b>	3.81" (97 mm)	3.42" (87 mm)	1.97" (50 mm)	1.06" (27 mm)
<b>X5 (min.)</b>	4.53" (115 mm)	4.53" (115 mm)	5.32" (135 mm)	4.76" (121 mm)
<b>X6</b>	5.12" (130 mm)	5.12" (130 mm)	3.15" (80 mm)	1.55" (39.5 mm)
<b>X7</b>	2.76" (70 mm)	2.76" (70 mm)	1.77" (45 mm)	6.69" (170 mm)

### Elevated Metal Base for Freestanding Installation (Models MFS18 and MFS25 only)

The elevated metal base for a freestanding installation must be constructed in the same way as the base for a secured installation. An additional U channel must be welded or bolted to the top of the front rail to secure the front washer mounting feet (see illustration below).

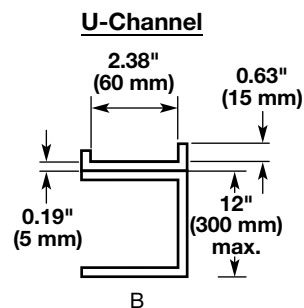
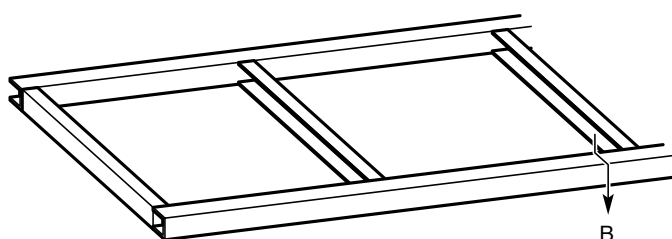

Dim.	Model			
	MFS18	MFS25	MFS35	MFS55
<b>A</b>	25.99" (660 mm)	25.99" (660 mm)	32.67" (830 mm)	35.46" (901 mm)
<b>B</b>	28.15" (715 mm)	32.48" (825 mm)	38.39" (975 mm)	36.40" (925 mm)
<b>C</b>	17.91" (455 mm)	22.24" (565 mm)	32.09" (815 mm)	33.30" (846 mm)
<b>D</b>	22.05" (560 mm)	22.05" (560 mm)	28.15" (715 mm)	31.50" (800 mm)
<b>X1</b>	1.14" (29 mm)	1.14" (29 mm)	1.18" (30 mm)	1.77" (45 mm)
<b>X2</b>	3.46" (88 mm)	3.46" (88 mm)	1.97" (50 mm)	1.06" (27 mm)
<b>X3</b>	1.97" (50 mm)	1.97" (50 mm)	2.26" (57.5 mm)	1.98" (50.5 mm)

# Electrical Requirements

## It Is Your Responsibility

- To contact a qualified electrical installer.
- To be sure that the electrical connection is adequate and in conformance with the National Electrical Code, ANSI/NFPA 70-latest edition, or Canadian Electrical Code CSA C22.1, and all local codes and ordinances.  
A copy of the above code standards can be obtained from: National Fire Protection Association, One Batterymarch Park, Quincy, MA 02269.
- To supply the required 3 or 4 wire, single phase, 208-240 volt, 60 Hz., AC electrical supply on a separate circuit. Circuit capacity is dependent on washer size and connection type and is shown in the tables below. A time-delay fuse or circuit breaker is recommended. Installation of a GFCI is also recommended. Connect to an individual branch circuit. Do not fuse the neutral or grounding circuit.
- A separate ground wire is recommended if codes permit. It is recommended that a qualified electrician determine the ground path is adequate.
- Coin-operated washers do not have an emergency stop switch. A remote emergency stop device must be installed. The switch must be easily accessible to all users and meet the requirements of ISO13850-category 0.

Model	Phase (Voltage)	
	1 (208-240V)	3 (208-240V)
MFS18	15A	15A
MFS25	15A	15A
MFS35	20A	20A
MFS55	Not Applicable	20A

### NOTES:

- Connecting these washers to IT power supplies requires special considerations.
- When installing multiple single phase washers into an existing 3-phase power supply, alternating the phase used as the hot leg is recommended to evenly distribute power on the system. See illustration.

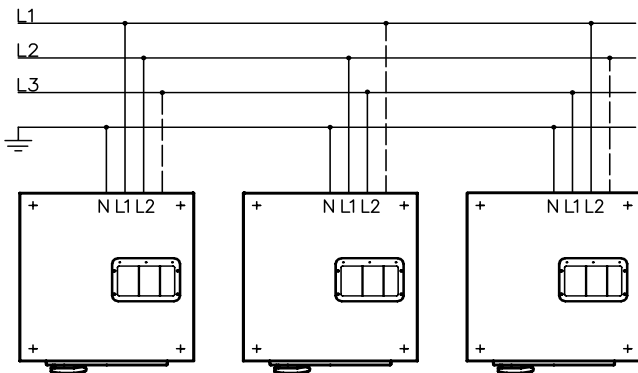

## Connection to Washer

These washers were designed for direct wiring into the power supply. The washer must be electrically grounded in accordance with local codes or, in the absence of local codes, with the National Electrical Code, ANSI/NFPA 70, latest edition, or Canadian Electrical Code, CSA C22.1, and all local codes and ordinances.

### Direct wire installation:

Power supply cable must match power supply (4-wire or 3-wire) and be:

- Flexible armored cable or nonmetallic sheathed copper cable (with ground wire), in a flexible metallic conduit. All current carrying wires must be insulated.
- Copper wire of appropriate gauge for amperage requirement (see table below). Stranded wire is recommended. Do not use aluminum wire.

Minimum Recommended Conductor Gauges	
Fuse or Breaker	Minimum AWG*
15A	14
20A	12

\*Copper stranded wire recommended.

### Equipotential bonding:

In addition to an equipment-grounding conductor that must be run with the circuit conductor and be connected to the equipment grounding terminal, all washers or appliances in the vicinity must be permanently interconnected with a protective connector.

The external protective connection points serve for this purpose (see illustration).

The cross-sectional area of the protective conductor must be at least electrically equivalent to the cross-sectional area of the copper conductor.

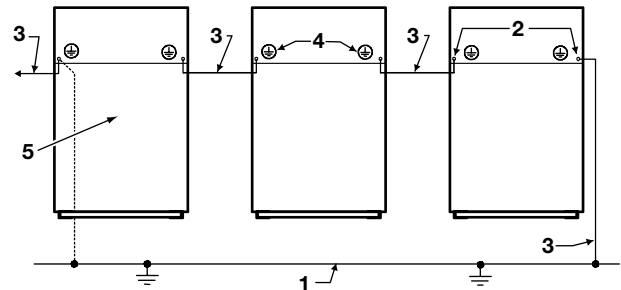

1. Protective grounding structure
2. External protective conductor connection point
3. Protective conductor
4. Grounding identification
5. Washer (rear view)

## Water Supply Requirements

### Water supply requirements:

- Valved hot and cold water supply with a water pressure between 14.5 and 116 PSI (100–800 kPa). Water pressure between 43 and 73 PSI (300–500 kPa) is recommended.
- A hot water heater or boiler supplying an adequate amount of water between 120–160°F (49–80°C). The water temperature within the washer is controlled to a maximum temperature that is set in the program. The amount of hot water required to wash a load of laundry is dependent on many factors, including the hot and cold water temperature and the wash program selected. Average amounts of hot water required to wash one load of laundry are shown in the table below.

Hot water requirement per load	
Washer Model	Hot water per load*
MFS18	4.0 gal. (15 L)
MFS25	4.5 gal. (16 L)
MFS35	8.0 gal. (31 L)
MFS55	10.5 gal. (40 L)

\*Approximate values. Assumes 140°F (60°C) hot water supply and 70°F (21°C) cold water supply.

- It is also necessary to connect all available water inlets to a water supply. If three inlets are present, then two should be cold water—one a hard water supply, and the other a soft water supply. If a hard and soft connection is not available, connect to whatever cold water supply is available.

## Drain Requirements

The washer has a 3" (75 mm) water drain on its rear side. A molded drain hose that extends up to 43" (1.09 m) and hose clamp are supplied with the washer. To maintain washer performance, do not reduce the diameter of the drain pipe.

The washer drain may drain into a waste channel or directly to a drain.

- The waste channel cannot be located under the washer. There should be at least 4" (100 mm) between the back of the washer and the middle of the waste channel (see illustration).
- The waste channel must be lower than the drain pipe. There should be at least a 3/4" (20 mm) air gap between the bottom of the drain and the water level in the channel.

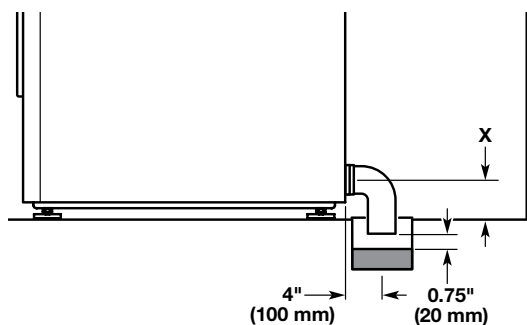

Minimum Waste Channel Measurements

	MFS18	MFS25	MFS35	MFS55
X	2.9" (73 mm)	2.9" (73 mm)	2.2" (55 mm)	5.5" (140 mm)

The drain pipe must be able to handle wastewater from all of the washers, so the diameter of the drain pipe required is dependent on the number of washers in the line. Sanitary drains must be vented and meet all local and municipal codes. The suggested drain diameter for one to three washers is shown in the illustration below.

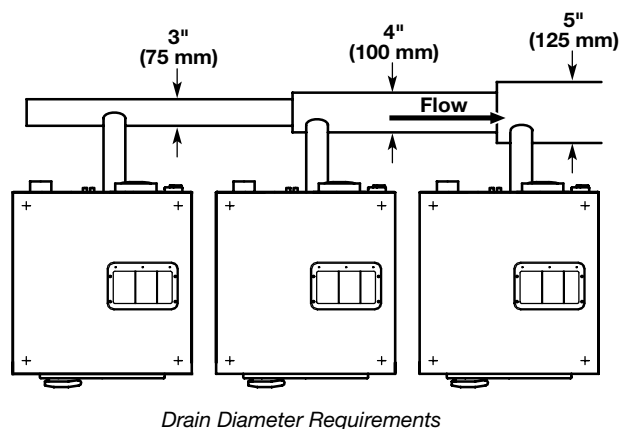

## Laundry Product Dispenser Pumps

### PN Models

Physical and electrical control connections for external liquid laundry product pumps are included in all PN models. If laundry product dispenser pumps will be used, the pumps should have an adequate flow rate to deliver the required amount of product to the dispenser within 30 seconds. Relay supply voltage was set at the factory. Check your material list for supply voltage.

### PD Models

It is also possible to connect external liquid laundry product pumps to PD model washers, but the following additional installation steps are required:

- It is necessary to complete the physical connection between the tubing connector and the dispenser.
- The electrical control connection to the liquid product pumps is made at the control panel inside the washer.

See "Laundry Product Supply Pump Connection" in "Installation Instructions" for additional information.



# ⚠ WARNING



## Electrical Shock Hazard

Disconnect power before servicing.

Replace all parts and panels before operating.

Failure to do so can result in death or electrical shock.

## Electrical Connection

1. Turn off power at fuse box or breaker box.
2. Open top of washer with key. Prop the top open with the support.
3. Remove approximately 6" (150 mm) of shielding from cable end to expose insulated wires. Be sure that there is sufficient wire to create a drip loop or wire sag, as shown.

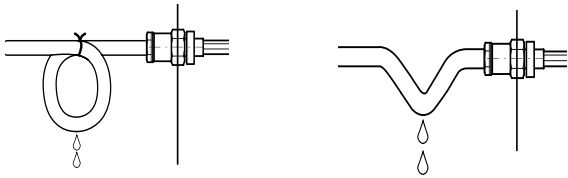

*A drip loop or wire sag keeps condensation from running into washer*

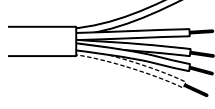
4. Strip wire insulation an adequate length to make connections. Install eyelets on ground wires with a crimping tool. 
5. Remove locking nut from strain relief provided with washer. Thread wire through strain relief and thread wire through hole in back of the washer until strain relief penetrates hole. Route strain relief nut around wires and tighten nut onto strain relief body.
6. Connect two or three current conducting wires into the connector and tighten the screw connectors; single phase and three-phase connections are shown in the illustrations. Attach ground to the frame ground bolt as shown in the illustrations and tighten the locking nut.

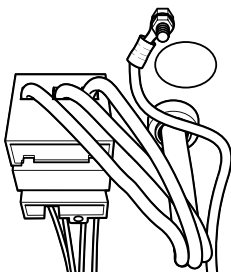

3-phase connection

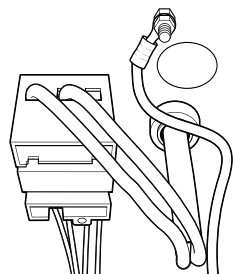

Single-phase connection

## Water Supply Connection

Connect the water supply to the washer using the flexible adapter hoses provided. Do not use a rigid connection for the water supply.

**NOTE:** The water connection to the washer requires a 3/4" British Standard Pipe Thread fitting. The ground end is a U.S. thread. Threading an NPT fitting or the NPT end of the adapter hose will damage the threads of the washer.

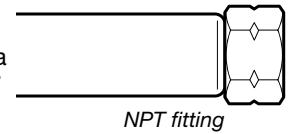

NPT fitting

1. Flush water lines to remove debris. Install the non-grooved side of the adapter hoses to the hot and cold side of the valves. Tighten fittings.
2. Attach grooved end of the adapter hoses to the washer. Tighten fittings.
3. Turn on water and check for leaks in the system.

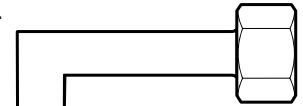

British standard pipe thread fitting

## Drain Connection

1. Cut the pre-formed drain hose assembly so it fits in the drain or drain channel.
2. Attach drain hose with clamp provided.

## Laundry Product Supply Pump Connection

Up to 8 laundry product supply pumps may be connected to the washer. Tubing and relay connections are provided in the back of the washer.

**NOTE:** Route hoses and wiring so they will not be pinched, damaged, or rubbed during use.

## Electrical Relay Connection

The electrical connections are relay connections only and do not provide adequate power for the pumps. The laundry product supply pump must be connected to a separate electrical source.

### PN Models

1. Turn off power at circuit breaker or fuse box.
2. Remove panel screw and remove cover. Connect relay leads to numbers 1 through 8. Connect ground to lead 10 using quick connects.
3. Replace cover.

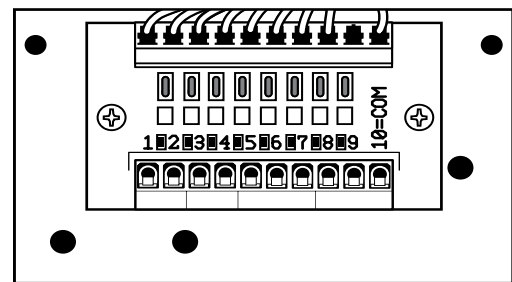

### PD Models

1. Turn off power at circuit breaker or fuse box.
2. Open top cover. Route control wires through washer and to relay connector on control panel. Connect leads.  
**NOTE:** Support control wires with wire ties to keep them away from moving parts.
3. Replace cover.

## Tubing Connectors

### All models

There are 6 tubing connectors in back of the washer. One connector is larger in diameter than the others. The larger diameter connector should be used for the pump requiring the highest flow rate. If you need additional chemicals, contact the manufacturer. Tubing connectors are sealed at the factory and must be drilled out before use.

### NOTES:

- Only drill out connectors that will be used. Any unused open connectors must be sealed to avoid reflux during the fill cycle.
  - Holes must be drilled. Attempting to open holes with a punch will damage the washer.
1. Drill out connectors that will be used. Use a drill bit slightly smaller than the interior diameter of the hole. Remove all debris from the hole. See illustration.

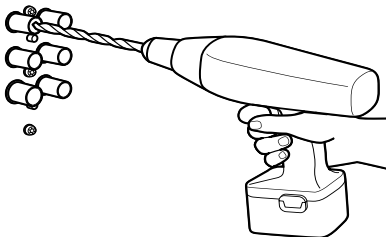

2. Attach flexible hoses rated for commercial laundry chemicals to the connectors. (Secure the hoses with a hose clamp.)

### PD models only

These additional steps are necessary to connect tubing connectors:

3. Open top cover. Locate connectors that were drilled. Attach tightly fitting flexible hoses rated for commercial laundry chemicals onto those connectors long enough to reach the dispenser connectors. Secure with a hose clamp.

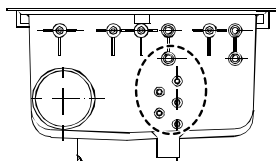

Dispenser connectors –  
Rear view

4. Be sure that dispenser connectors fit the hoses. Drill out connectors on the dispenser with a drill bit slightly smaller than the interior diameter of the hole. Remove all debris from the hole.
5. Attach flexible hoses rated for commercial laundry chemicals to the connectors. Secure the hoses with a hose clamp.

## Complete Installation

### ⚠ WARNING



#### Electrical Shock Hazard

**Disconnect power before servicing.**

**Replace all parts and panels before operating.**

**Failure to do so can result in death or electrical shock.**

1. Be sure that the shipping brackets are removed.
  2. Open door and be sure that the washer drum is empty.
  3. Verify that washer is level and does not rock from side-to-side.
  4. Check electrical connection and ground.
  5. Turn on water.
  6. Adjust vibration switch. See “Vibration Switch Adjustment” in Maintenance.
  7. Check drain connection and clearance.
  8. Turn power on at circuit breaker.
  9. Turn the washer on. Begin a wash cycle. Watch the drum during the extraction cycle. The drum should rotate clockwise as observed from the front of the washer.
  10. Ensure all panels are installed.
- IMPORTANT:** If the drum rotates counter-clockwise, turn off the power supply at the circuit breaker and reverse the polarity of the supply wires from the frequency inverter to the motor. This should only be performed by qualified personnel.
11. Perform vibration switch function test (see Vibration Switch Adjustment and Function Test).
  12. Begin wash cycle again. Activate the emergency stop switch. All electrical power to the washer should be deactivated.

## Break-In Period

The following checks and adjustments should be performed during the break-in period as follows:

### 24 operation hours

- Check belt tightness. See “Belt Inspection and Adjustment” in Maintenance.

### 80 operation hours

- Check belt tightness. See “Belt Inspection and Adjustment” in Maintenance.
- Check mounting bolt tightness. Retighten if necessary (secured installation only).

## Controls Troubleshooting

For programming and controls troubleshooting, refer to the Programming Guide.

# WASHER MAINTENANCE

## Maintenance Schedule

### After Each Load

- Remove debris from the wash drum including paper clips, coins, and other hard items.
- When not in use, leave the washer door open to allow the washer to air out and prolong gasket life.

### Daily Maintenance

- Clean water, detergent, and other stains off of the washer with a soft cloth dampened with a mild detergent solution.
- Dry with a soft cloth. Do not use abrasives.
- Clean detergent residue and other contamination off the door seal with a soft cloth dampened with a mild detergent solution.
- Remove residue from the laundry product hoppers with a plastic scraper. Wipe the hoppers with a soft cloth dampened with water.
- Check water and steam inlets for leaks. Correct as necessary.

### Maintenance Every 500 Hours or 3 Months

## ⚠ WARNING



### Electrical Shock Hazard

**Disconnect power before servicing.**  
**Replace all parts and panels before operating.**  
**Failure to do so can result in death or electrical shock.**

- Observe the washer from the back for one wash cycle. Be sure that water does not leak out of the drain during the wash part of the cycle and that it drains freely at the beginning of extraction. Clean the drain if either of these symptoms are observed.
1. Turn off power to washer at the circuit breaker or fuse box.
  2. Unlock top cover of washer, remove dispenser screws, and open top (see Top View on page 15 for location of dispenser). Remove bolts securing rear panel of washer.
  3. Inspect all hoses and connections inside the washer for leaks and correct as necessary. Remove dust and debris from inside the washer with a shop vacuum and soft bristled attachment. Pay particular attention to the motor cooling fins, inverter cooling fins, cooling fans, and vents.
  4. Wipe up any stains with a soft cloth dampened with water or a mild detergent solution. Be sure that control components are not exposed to dust and moisture during cleaning.
  5. Check that all bolts are properly torqued.
  6. Turn on power at circuit breaker or fuse box.

### Maintenance Every 1000 Hours or 6 Months

- Turn off hot and cold water to the washer at the the valves. Clean water filters.
- Be sure ventilator fans are functioning (some models).
- Inspect belt and check belt tension. See Belt Inspection, Adjustment, and Replacement.
- Check mounting bolt tightness. Retighten if necessary (fixed installation only).

### Maintenance Every 2000 Hours or 12 Months

- Adjust and perform functional test on vibration switch (see Vibration Switch Adjustment and Function Testing).

## Vibration Switch Adjustment and Function Test

## ⚠ WARNING



### Electrical Shock Hazard

**Disconnect power before servicing.**  
**Replace all parts and panels before operating.**  
**Failure to do so can result in death or electrical shock.**

The Vibration Switch is a critical component of the washer that avoids washer damage during extraction of an unbalanced load. Vibration Switch adjustment must be performed during installation and checked annually. The Vibration Switch is located toward the front of the washer on top of the drum and can be accessed by opening the top cover.

### Vibration Switch Adjustment

1. If washer was just installed, run washer through one complete extraction cycle without a load so the drum is at its balance point.
2. Turn off power to washer at the circuit breaker or fuse box.
3. Unlock top cover of washer, remove dispenser screws, and open top (see Top View on page 15 for location of dispenser). Prop up the front of the cover.
4. Locate vibration switch assembly. Check floating arm adjustment. Loosen the static arm bolts to adjust distance.

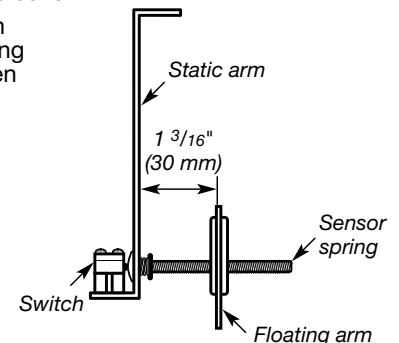

Floating arm distance adjustment

- Be sure that the sensor spring is roughly centered in the floating arm slot horizontally and about 1/3 of the way from the bottom vertically.

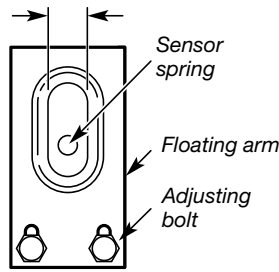

Centering Sensor Spring – Front View

- Adjust switch gap with a feeler gauge (see illustration). Loosen adjustment screws when adjusted properly.

- Turn on power at circuit breaker or fuse box.

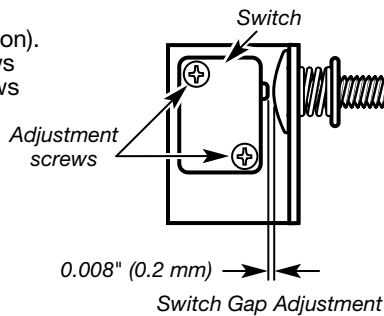

Switch Gap Adjustment

### Vibration Switch Function Test

- Begin extraction cycle with no load in the washer.
- Unlock top cover of washer, remove dispenser screws, and open top (see Top View on page 15 for location of dispenser). Prop up the front of the cover. Locate vibration sensor assembly.
- Push down on the spring sensor with a screwdriver or other long-handled tool. The extraction cycle should stop. If extraction does not stop, the sensor requires adjustment or is defective.

### Belt Inspection, Adjustment and Replacement

#### ⚠ WARNING



#### Electrical Shock Hazard

Disconnect power before servicing.

Replace all parts and panels before operating.

Failure to do so can result in death or electrical shock.

### Belt Inspection and Adjustment

- Turn off power to washer at the circuit breaker or fuse box.
- Remove bolts securing the rear panel of washer. Remove rear panel. Inspect belt for signs of wear and damage. Replace the belt if worn or damaged. See "Belt Replacement".
- Be sure that the belt pulleys are aligned by laying a straight edge along the drum pulley. The motor pulley should be in line with the straight edge. If the pulleys are not aligned, loosen the motor mounting bolts and adjust. Re-tighten motor mounting bolts.

- Checking the belt tension requires a straight edge and a belt tension gauge. Place the straight edge from the drum pulley to the motor pulley. Belt tension is correct when a 13 lb. (60 N) force applied to the midpoint of the belt between the two pulleys deflects the belt 9/16 to 3/4" (15–20 mm). To adjust the belt, first loosen the locking nut and loosen or tighten the belt as necessary. Re-tighten the locking nut when adjusted and re-check.

- Replace rear panel of washer. Turn on power at circuit breaker or fuse box.

### Belt Replacement

- Turn off power to washer at the circuit breaker or fuse box.
- Remove bolts securing the rear panel of washer. Remove rear panel.
- Loosen locking nut and loosen belts. On Models MFS18 and MFS25, it is necessary to press on the motor to remove the belts. Do not use a prybar or screwdriver to remove the belts except to hold up the motor.
- Replace with new belts of the same type.
- Adjust belts. See "Belt Inspection and Adjustment".
- Replace rear panel of washer. Turn power on at circuit breaker or fuse box.

### Door Seal Adjustment and Replacement

Water leaks around the door seal may occur as the gaskets age. In most cases, this can be resolved through door adjustment. In severe cases, seal replacement is necessary. These procedures are discussed here.

#### Door Seal Adjustment (Models MFS18 and MFS25)

- Remove the front cover around the latch. Set cover aside.
- Increase (decrease) door seal pressure on the hinge and latch sides by removing (inserting) spacer shims between the hinge or latch and door frame. Tighten bolts and locking nuts.
- Be sure that the door pin is in the center of the door lock opening. Loosen the hinge screws slightly to reposition the door, if necessary. Open the door and re-tighten the screws/bolts when the pin is centered. Add a screw lock when secured.
- Check the gasket pressure. Open door and close door latch on the door. Close the door until the closed door latch contacts the roller. Slowly release pressure on the door and allow the door to spring back. Measure the distance between the roller and latch without pressure on the latch. Gasket pressure is correct when the distance is 0.2–0.4" (5–10 mm).

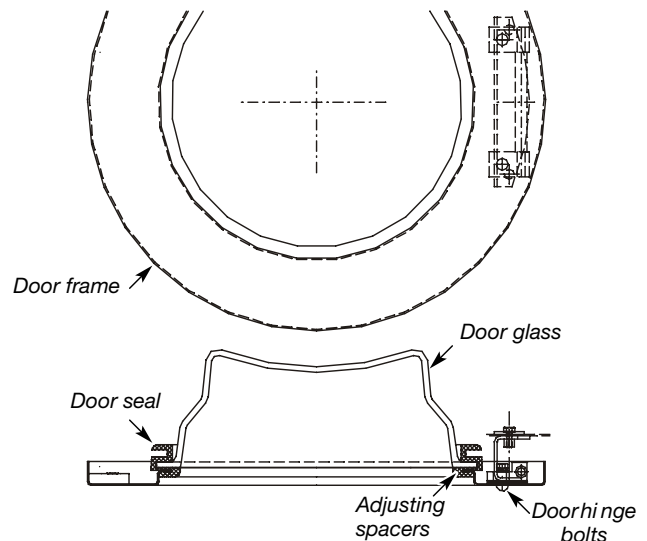

Door Seal (Models MFS18 and MFS25)

### Door Seal Adjustment (Models MFS35 and MFS55)

1. To adjust pressure on the hinge side, open the door and loosen the door frame bolts clamping the door frame to the hinge. Take out the square washers. Tighten the bolts. Loosen the door hinge bolts. Insert one, two or three square washers between the longitudinal beam and the cross beam as needed. Tighten door hinge bolts when adjusted.
2. To adjust pressure on the latch side, remove the lock cover bolts and lock cover. Remove the door lock bolts. Remove distance lock washers as needed. Replace door lock and latch.
3. Be sure that the door pin is in the center of the door lock opening. Loosen the hinge screws slightly to reposition the door, if necessary. Open the door and re-tighten the bolts when the pin is centered.
4. Check gasket pressure. Open the door and close door latch handle while the door is open. Slowly close the door until the door latch contacts the roller. Release pressure on the door slowly; the door should spring back slightly. Measure the distance between the roller and latch without pressure on the latch. Gasket pressure is correct when the distance is 0-0.2" (0-5 mm).

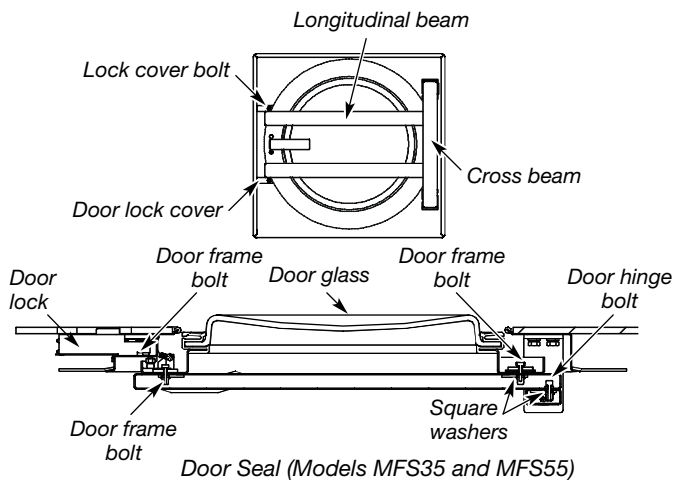

### Door Seal Replacement

1. Open the door. Remove the door glass with rubber from the door frame by pushing it toward the drum. Do not damage the glass.
2. Separate the gasket from the glass.
3. Place a new rubber gasket with the wider groove on the glass with the edge up.
4. Moisten the seal groove gasket with soapy water. Place a smooth cord in the groove so it goes around the entire circumference. Fit the assembly to the door frame. Hold one end of the cord firmly on the door. Pull the other cord end toward the center of the glass and work the gasket onto the door.

### Fuse Replacement

All washers have 2-1A in-line fuses at the back of the washer. Model MFS55 has an additional 0.5 A in-line fuse.

### Opening Door Without Power

## ⚠ WARNING



### Electrical Shock Hazard

**Disconnect power before servicing.**

**Replace all parts and panels before operating.**

**Failure to do so can result in death or electrical shock.**

In case of a power failure, the door may not open.

To open the door without power:

1. Turn off power supply at the circuit breaker or fuse box.
2. Remove the front service panel.
3. Find the emergency cord on the left side of the washer. Pull the cord firmly until you hear a faint click. Open door.
4. Replace front service panel.
5. Turn on power at circuit breaker or fuse box.

# DIMENSIONS AND TECHNICAL SPECIFICATIONS

## Dimensions

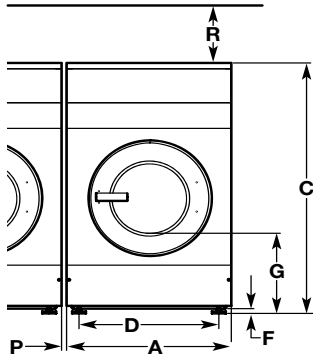

Front View (Models MFS18 and MFS25)

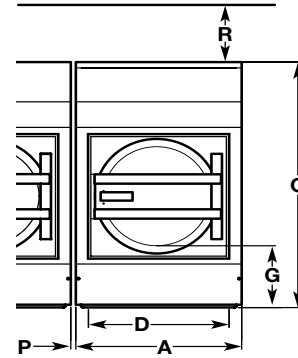

Front View (Models MFS35 and MFS55)

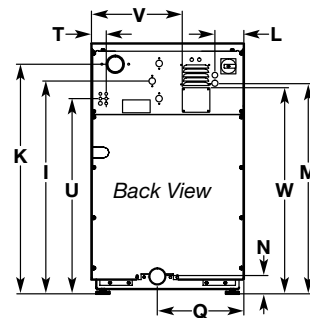
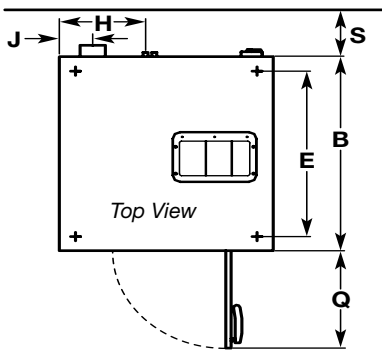

	<b>MFS18</b>	<b>MFS25</b>	<b>MFS35</b>	<b>MFS55</b>
<b>A</b>	25.99" (660 mm)	25.99" (660 mm)	32.67" (830 mm)	35.46" (901 mm)
<b>B</b>	28.15" (715 mm)	32.48" (825 mm)	38.39" (975 mm)	36.40" (925 mm)
<b>C</b>	42.50" (1080 mm)	44.90" (1140 mm)	51.00" (1295 mm)	56.50" (1435 mm)
<b>D</b>	22.10" (560 mm)	22.10" (560 mm)	28.20" (715 mm)	31.50" (799 mm)
<b>E</b>	17.91" (455 mm)	22.24" (565 mm)	32.09" (815 mm)	33.30" (846 mm)
<b>F</b>	0.80" (20 mm)	0.80" (20 mm)	—	—
<b>G</b>	15.50" (420 mm)	18.90" (480 mm)	16.90" (430 mm)	23.00" (585 mm)
<b>H</b>	10.40" (263 mm)	10.40" (263 mm)	11.80" (300 mm)	10.40" (263 mm)
<b>I</b>	35.80" (910 mm)	38.20" (970 mm)	44.70" (1135 mm)	48.20" (1225 mm)
<b>J</b>	4.10" (103 mm)	4.10" (103 mm)	4.70" (120 mm)	4.10" (103 mm)
<b>K</b>	38.60" (980 mm)	40.90" (1040 mm)	47.00" (1195 mm)	51.80" (1315 mm)
<b>L</b>	1.70" (44 mm)	1.70" (44 mm)	1.70" (44 mm)	17.70" (450 mm)
<b>M</b>	32.90" (835 mm)	35.20" (895 mm)	40.00" (1015 mm)	50.60" (1285 mm)
<b>N</b>	3.10" (78 mm)	3.10" (78 mm)	2.20" (55 mm)	5.50" (140 mm)
<b>O</b>	14.80" (375 mm)	14.80" (375 mm)	16.30" (415 mm)	28.30" (720 mm)
<b>P</b>	0.60" (15 mm)	0.60" (15 mm)	0.80" (20 mm)	0.80" (20 mm)
<b>Q</b>	17.50" (445 mm)	17.50" (445 mm)	20.90" (530 mm)	20.90" (530 mm)
<b>R</b>	27.60" (700 mm)	27.60" (700 mm)	27.60" (700 mm)	27.60" (700 mm)
<b>S</b>	23.60" (600 mm)	23.60" (600 mm)	23.60" (600 mm)	23.60" (600 mm)
<b>T</b>	2.70" (68 mm)	2.70" (68 mm)	7.87" (200 mm)	6.61" (168 mm)
<b>U</b>	33.50" (850 mm)	33.50" (850 mm)	41.70" (1060 mm)	42.90" (1092 mm)
<b>V</b>	—	13.30" (339 mm)	18.50" (470 mm)	17.50" (445 mm)
<b>W</b>	—	34.40" (874 mm)	41.40" (1052 mm)	44.90" (1140 mm)

## Component Locations

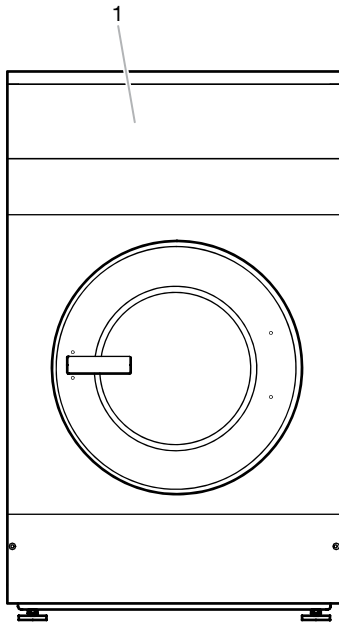

Front View (Models MFS18 and MFS25)

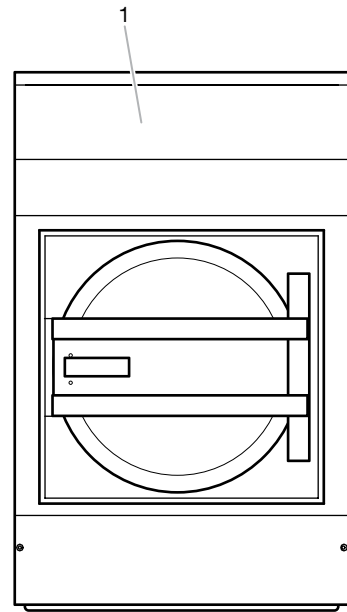

Front View (Models MFS35 and MFS55)

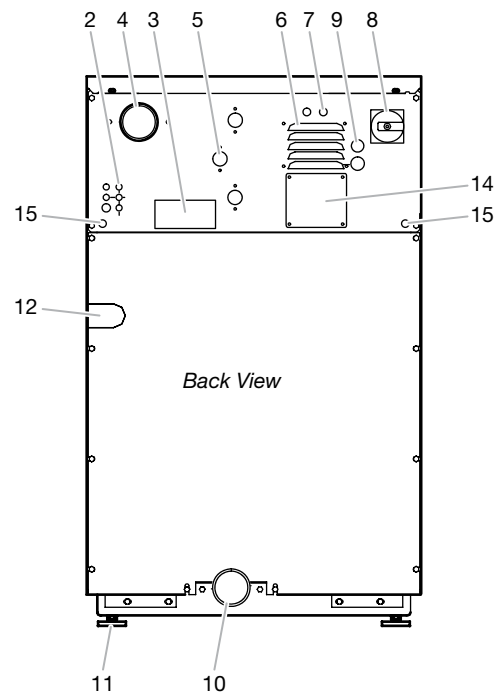
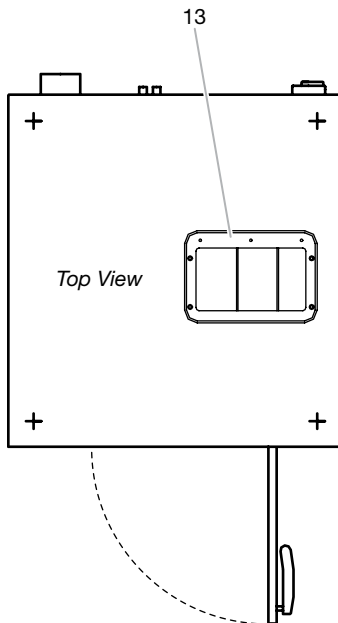

1. Control panel
2. Connection liquid soap
3. Serial plate
4. Air relieve
5. Water supply
6. Air vent holes,  
Frequency inverter
7. Fuses
8. Main switch

9. Electrical supply connection
10. Drain
11. Adjustable feet
12. Steam connection
13. Soap dispenser
14. Liquid soap relay board box
15. Earth connection

## Technical Specifications

	MFS18	MFS25	MFS35	MFS55
<b>Dimensions and Weights</b>				
Washer dimensions (width x depth x height)	25.99 x 28.15 x 42.50" (660 x 715 x 1080 mm)	25.99 x 32.48 x 44.90" (660 x 825 x 1140 mm)	32.67 x 38.39 x 51.00" (830 x 975 x 1295 mm)	35.46 x 36.40 x 56.50" (901 x 925 x 1435 mm)
Net weight	519 lb. (235 kg.)	607 lb. (275 kg.)	1026 lb. (465 kg.)	1433 lb. (650 kg.)
Package dimensions	29.50 x 33.50 x 49.30" (750 x 850 x 1250 mm)	29.50 x 37.40 x 51.20" (750 x 950 x 1300 mm)	36.60 x 44.90 x 59.50" (930 x 1140 x 1510 mm)	38.40 x 47.30 x 63.80" (975 x 1200 x 1620 mm)
Gross weight	552 lb. (250 kg.)	662 lb. (300 kg.)	1092 lb. (495 kg.)	1522 lb. (690 kg.)
Transportation volume	27.9 cu.ft. (0.8 m <sup>3</sup> )	32.5 cu.ft. (0.9 m <sup>3</sup> )	56.5 cu.ft. (1.6 m <sup>3</sup> )	67.1 cu.ft. (1.9 m <sup>3</sup> )
<b>Electrical Requirements</b>				
Supply Voltage (50/60 Hz)	208–240V 1-phase*			208–240V 3-phase
Fuse/Breaker Type	Slow (curve D)			
GFCI**	Class B			
<b>Water Supply Requirements</b>				
Allowable water pressure	14.5–116 psi (100–800 KPa)			
Recommended pressure	43–73 psi (300–500 KPa)			
Water inlet	BSP 3/4"			
Maximum water temperature	194°F (90°C)			
<b>Drain Requirements</b>				
Drain diameter	3" (76 mm)			
Flow rate	56 GPM (3.5 l/s)			
<b>Environmental Requirements</b>				
Operating temperature	41 to 95 °F (5 to 35°C)			
Relative humidity	30 to 90 % without condensation			
Elevation above sea level	Up to 3280 ft. (1,000 m)			
Storage temperature	32 to 131°F (0 to 55°C)			
<b>Floor Requirements</b>				
Maximum static load	560 lb. (2492 N)	675 lb. (3002 N)	1225 lb. (5450 N)	1770 lb. (7860 N)
Maximum dynamic load	164 lb. (730 N)	248 lb ( 1100 N)	275 lb. (1220 N)	366 lb. (1626 N)
Dynamic frequency	16 Hz	16 Hz	16 Hz	15 Hz
<b>Noise</b>				
Noise output	<70 dB(A)	<70 dB(A)	<70 dB(A)	<70 dB(A)
<b>Steam Connection</b> G 1/2"				
Low pressure				14.5–44 PSI (100–303 KPa)
High pressure				44–116 PSI (303–800 KPa)

\* 2 phases of a 3-phase power supply may be used. See "Electrical Requirements".

\*\* Consult an electrician to ensure proper GFCI connection.

## Torque Specifications

Recommended Torque Values for Steel Bolts	
Bolt Size	Torque
M6	8 ft. lbs. (10 Nm)
M8	20 ft. lbs. (25 Nm)
M10	35 ft. lbs. (45 Nm)
M12	60 ft. lbs. (80 Nm)
M16	150 ft. lbs. (200 Nm)

**W10214572B**

© 2010  
All rights reserved.

® Registered Trademark/TM Trademark of Maytag Corporation or its related companies.  
Used under license by Maytag Limited in Canada.

07/2010  
Printed in Czech Republic